

Sound engineer : Titus (+336 07 41 32 50)

Titus.wathier@gmail.com

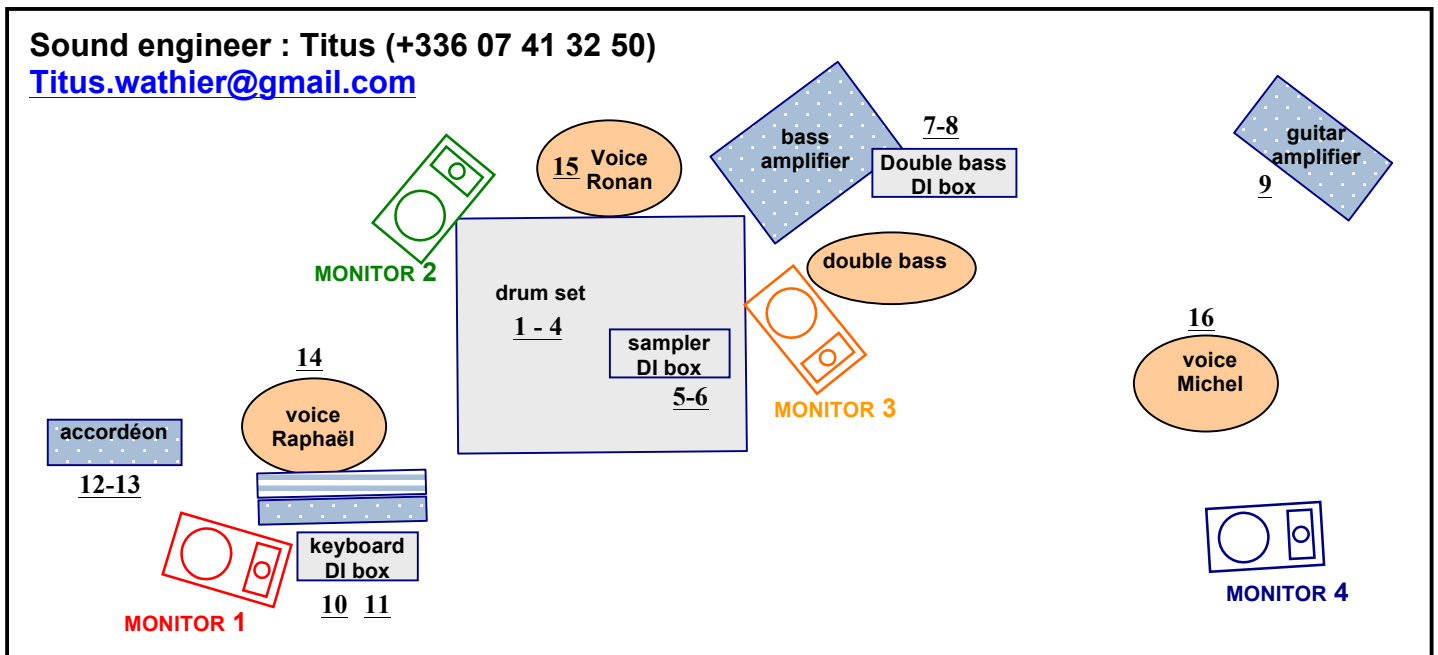

We come with our own mixboard Soundcraft SI Compact 24, with stage box and digital multicore (RJ45)(50 meters)

If we can't use our mixboard, we need :

Mixboard 32/8/8/2 (Midas, Soundcraft)

Inserts : DRAWMER, BSS, DBX...

Effects : LEXICON reverb + YAMAHA SPX 990...

Equaliseurs on PA and Monitors, 2x31 type BSS, APEX.

N° instrument	micro	insert
1 Kick	supplied micro	comp
2 Snare 1	supplied micro	comp
3 Snare bottom 1	supplied micro	comp
4 HiHat	451 – sm81	small stand
5 SPDS L	DI box	
6 SPDS R	DI box	
7 Double Bass	DI box	comp
8 Double Bass	supplied micro	comp small stand
9 Guitar	supplied micro	
10 Keyboard L	DI box	comp
11 Keyboard R	DI box	comp
12 Accordéon L	XLR	comp
13 Accordéon R	XLR	comp
14 Voice Raph	supplied micro	comp big stand
15 Voice Ronnan	supplied micro	comp big stand
16 Voice Michel	Sm58	comp big stand

PA :

Equipment with sub bass. We need 100dB mini.

Stage :

Forcast equipment :

- . 1 Senheiser 451 or sm81 ; 1 sm58
- . 5 actives DI Box
- . 12 compressors
- . 2 small stands ; big stands
- . 1 riser 2m x 2m for the drum set,
- . 3 power supplies on stage

Monitors :

4 monitors for 4 pré-fader mix on stage (NEXO PS 15, C. HEIL MTD 115...)

Install :

We need 30 mn for the installation, and 1 hour for the sound check.